

# Literature Review on Abrasive Jet Machining

<sup>1</sup>Tarun Batra and <sup>2</sup>Devilal

*<sup>1,2</sup>Master of engineering, Branch-manufacturing technology, National institute of teachers technical training and research, chandigarh, email: Batratarun32@yahoo.com*

---

## ABSTRACT

A machining operation is basically termed a material removal process, where material is removed in the form of chips. In a machining operation, the output parameter is achieved by controlling various input parameters. This paper discusses the effects of various input parameters in abrasive Jet machining (AJM) on the output parameter (Metal Removal Rate [MRR]). This paper presents an extensive review of the current state of research and development in the abrasive jet machining process. Further difficulties and future development in abrasive jet machining are also projected. This review paper will help researchers, students, manufactures to understand policy makers widely.

**KEYWORDS:** Abrasive jet machining, Erosion rate, Nozzle tip distance, Material removal rate (MRR), Glass, versatility, Flexibility, Stand-off distance (SOD), Non-Traditional.

---

## 1. INTRODUCTION

Abrasive jet machining (AJM) is a processing nontraditional machine which operators on no physical contact between tool and work piece so there is no thermal stresses and shocks developed. AJM is applied for many applications like cutting, cleaning, polishing, deburring, etching, drilling and finishing operation. In Abrasive jet machining abrasive particles are made to impinge on work material at high velocity. Jet of abrasive particles is carried by carrier gas or air. The high velocity stream of abrasives is generated by converting pressure energy of carrier gas or air to its Kinetic energy and hence high velocity jet. Nozzles directs abrasive jet in a controlled manner onto work material. The high velocity abrasive particles remove the material by micro-cutting action as well as brittle fracture of the work material.

The process parameters are used like variables which effect metal removal. They are carrier gas, abrasive, and velocity of abrasive, work material, and nozzle tip distance (NTD). Abrasive jet

cutting is used in the cutting of materials like: Titanium, Brass, Aluminum, Stone, Any Steel, Glass, Composites, Plastics, Ceramics, Tungsten carbide etc.

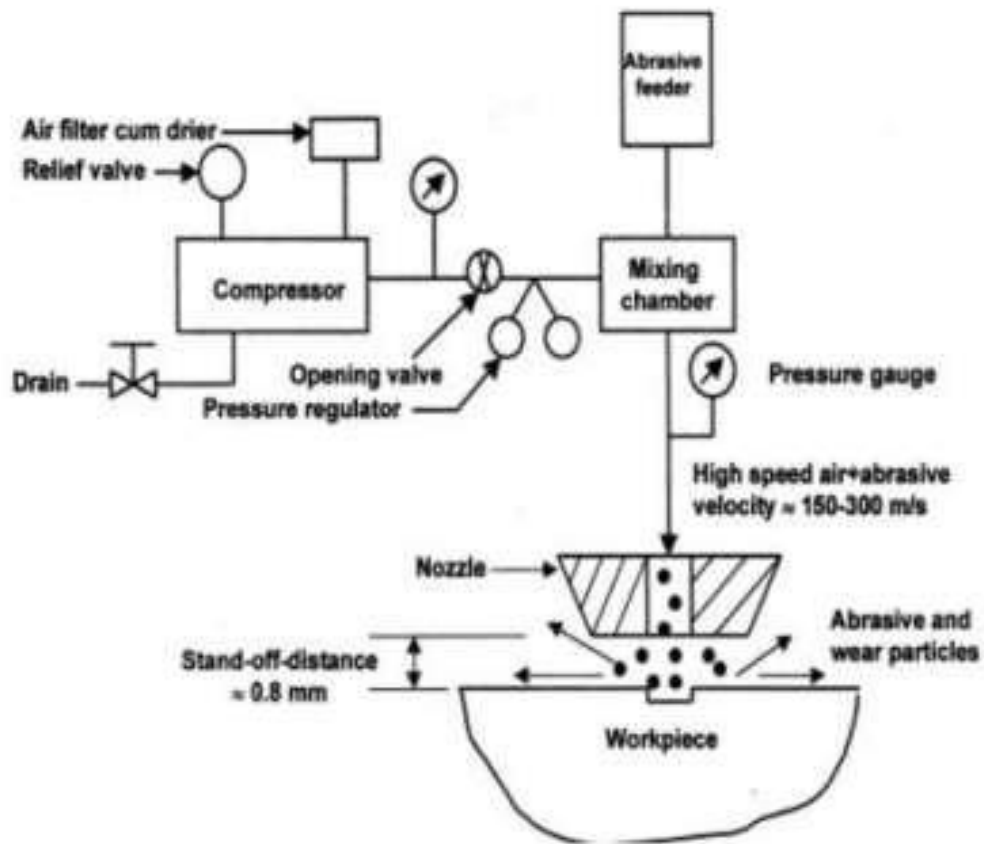

Fig.1 Schematic Diagram of AJM

## 2. BACKGROUND

This novel technology was first initiated by Franz to cut laminated paper tubes in 1968 and was first introduced as a commercial system in 1983... In the 1980s garnet abrasive was added to the water stream and the abrasive jet was born. In the early 1990s, water jet pioneer Dr. John Olsen began to explore the concept of abrasive jet cutting as a practical alternative for traditional machine shops. His end goal was to develop a system that could eliminate the noise, dust and expertise demanded by abrasive jets at that time. In the last two decades, an extensive deal of research and development in AJM is conducted.

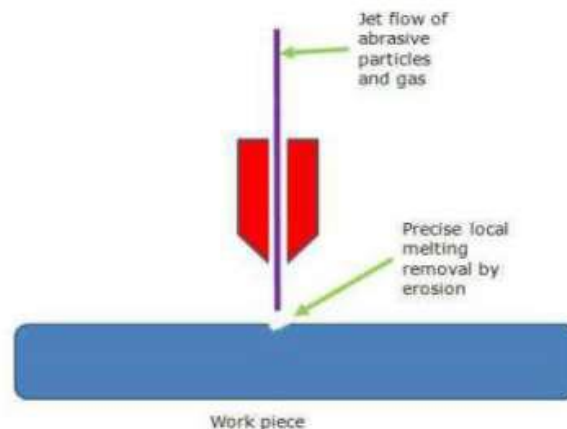

Fig.2 Material Removal by Erosion

## 3. LITERATURE REVIEW

In this section the experimental analysis of Abrasive jet machining is discussed. The experimentations conducted by various researchers by influencing the abrasive jet machining (AJM) process parameters on material removal rate, Surface integrity, kerf are discussed. The parameters like SOD, Carrier gas, Air Pressure, Type of Abrasive, Size, Mixing Ratio etc. are focused.

Dr. M. Sreenevasa Rao [1] reviewed that Ingulli C. N. (1967) was the first to explain the effect of abrasive flow rate on material removal rate in AJM. Along with Sarkar and Pandey (1976) concluded that the standoff distance increases the MRR and penetration rate increase and on reaching an optimum value it start decreasing. J. Wolak (1977) and K. N. Murthy (1987) investigated that after a threshold pressure, the MRR and penetration rate increase with nozzle pressure. The maximum MRR for brittle and ductile materials are obtained at different impingement angles. For ductile material impingement angle of 15-20 results in maximum MRR and for brittle material normal to surface results maximum MRR.

Dr.A. K. Paul &P. K. Roy (1987) [2]Carried out the effect of the carrier fluid (air) pressure on the MRR, AFR, and the material removal factor (MRF) have been investigated experimentally on an indigenous AJM set-up developed in the laboratory. Conducted Experimentation on the cutting of Porcelain with Sic abrasive particles at various Air pressures. Observed that MRR has increased with increase in grain size

and increase in nozzle diameter. The dependence of MRR on standoff distance reveals that MRR increases with increase in SOD at a particular pressure.

Finnie (1960) [3]showed that volume of Material (Q) eroded by impacting Particles of mass M carried in a stream of air can be calculated as

$$Q = C_f (\theta) M v^n,$$

Where C & n are constants  $H_s$  =Minimum flow stress of work material, I is Impingement Angle.

Sarkar & Pandey (1980)[4] suggested a model to calculate MRR (Q) during AJM.

$$Q = x Z d^3 v^{3/2} (8/12 H_w)^{3/4},$$

Where Z is no of particles impacting per unit time, D is the mean diameter of Abrasive grain, K is the density, V is the velocity of abrasive particles, H is hardness of work material, X is a constant.

Ghobeity et al. [5] have experimented on process repeatability in abrasive jet machining. They mentioned that many applications have several problems inherent with traditional abrasive jet equipment. Poor repeatability in pressure feed AJM system was traced to uncontrolled variation in abrasive particle mass flux caused by particle packing and local cavity formation in reservoir. Use of mixing chamber improved the process repeatability. For finding out process repeatability they measured depth of machined channel.

Ghobeity et al. [6] stated that particle distribution can greatly affect the shape and depth of profile. Analytical model has developed with by considering the particle size distribution. It results that if particle size distributed uniformly it helps to maintain uniform velocity of abrasive jet which causes improvement in MRR.

El-Domiaty et al. [7] did the drilling of glass with different thicknesses have been carried out by Abrasive jet Machining process (AJM) in order to determine its machinability under different controlling parameters of the AJM process. The large diameter of the nozzle lead to the more abrasive flow and which lead to more material removal rate and lower size of abrasive particle lead to the low material removal rate. They have introduced an experimental and theoretical analysis to calculate the material removal rate.

Shanmugam and Masood (2009)[8]presented an investigation on the kerf taper angle generated by abrasive water jet (AWJ) technique to machine two types of composites: epoxy pre-impregnated

graphite woven fabric and glass epoxy. Comprehensive factorial design of experiments was carried out in varying the traverse speed, abrasive flow rate, standoff distance and water pressure

Stephen Wan et al. (2010)[9] present simple deterministic process models for the prediction of the evolution of the cross-sectional profile of the glass channels generated by erosive wear in micro air abrasive jet machining using a round nozzle. Experiments were carried out on soda lime and borosilicate glass to verify the process models. Predicted model results show fairly good agreement with experimental results.

R. Balasubramaniam et al. [10] stated that as the particle size increases, the MRR at the central line of the jet drastically increases; but the increase in MRR nearer to the periphery is very less. As the stand-off distance increases the entry side diameter and the entry side edge radius increases, Increase in stand-off distance also increases MRR. As the central line velocity of jet increases, the MRR at the central line of the jet drastically increases. But there is no increase in MRR nearer to the periphery of the jet. The increase in entry side diameter and edge radius is not significant. As the peripheral velocity of the jet increases, the edge radius and entry side diameter increase. It also increases the MRR.

R. H. M. Jafar et al (2013)[11] presented experimental data on the effect of particle size, velocity, and angle of attack on the Surface roughness of unmasked channels machined in borosilicate glass using AJM. Single impact experiments were conducted to quantify the damage due to the individual alumina particles. Based on these observations, the assumed location of lateral crack initiation in a relatively simple analytical model from the literature was modified, and used to predict the roughness and erosion rate.

Jukti Prasadn Padhy [12] carried the drilling experiment on glass work piece using aluminum oxide as abrasive powder. Experimental work was done by considering stand-off distance (SOD) and pressure as machining parameter to study material removal rate (MRR) and overcut (OC). The effect of observed value of MRR and OC was analyzed by Taguchi design. From analysis it was concluded that the pressure and SOD both are significant for MRR and only pressure is significant for OC. Individual optimal settings of parameters are carried out to minimize the OC and maximize the MRR.

V. C. Venkatesh, T. N. Goh et al (1989)[13] reported a study of the results of machining under various conditions. A commercial AJM machine was used, with nozzles of diameter ranging from 0.45 to 0.65 mm, the nozzle materials being either tungsten carbide or sapphire, both of which have high tool lives. Silicon carbide and aluminum oxide were the two abrasives used. The materials machined were glass, ceramics, and electro-discharge machined (EDM) dies steel.

Mr. Bhaskar Chandra [14] Studied the variation in Material Removal Rate according to change in Gas pressure and Hole diameter according to change in NTD. Various experiments were conducted on work piece material- glass using abrasive material alumina. The effect of gas pressure on the material removal rate is shown in fig 3.

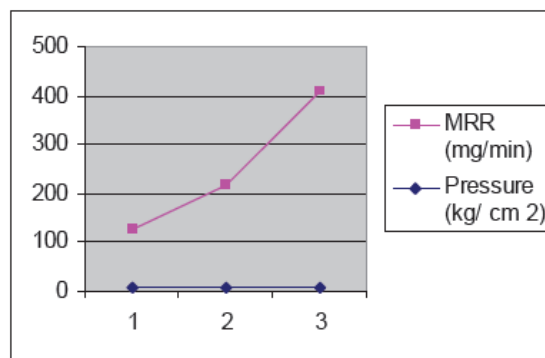

Fig.2 Graph shows the Relationship between pressure and material removal rate (MRR) at thickness 8 mm and NTD 12 mm.

#### 4. CONCLUSION

According to the various research papers available till date, lot of work has done on abrasive particles and its geometry, different process parameters, volume of material removal during machining. An extensive review of the research and development in the AJM has been conducted in this paper. It was shown that AJM process is receiving more and more attention in the machining areas, particularly for the processing of difficult-to-cut materials. Its unique advantages over other conventional and un-conventional methods make it a new choice in the machining industry. Very less research has been done on study of effect of abrasive flow rate on performance characteristics. Hence there is scope for improvement for the study of effect of abrasive flow rate on performance characteristics like material removal rate and taper angle. Improper mixing chamber construction causes various problems such as abrasive powder stratification, powder compaction, powder humidification etc. This affects the machining results undesirably.

#### 5. REFERENCES

1. Ingulli.C.N,” Abrasive Jet Machining ”Tool and Manufacturing Engg –Vol-59 p-28-1967.
2. Dr. A. k. Paul &R. K. Roy “some studies on Abrasive jet machining the Journal of the Institution of Engineers (India) Vol 68 part PE 2 November 1987.
3. Finnie. 'Erosion of Surface by Solid Particles'. Welr, vol 3,1960.
4. P K Sarkar and P C Pandey. 'Some Investigations on the Abrasive Jet Machining', Journal of the Institution of Engineers (India), Vol 56, ME 6, 1976.
5. A. Ghobeity, H. Getu, T. Krajac, J. K. Spelt, M. Papini. "Process repeatability in abrasive jet micro-machining". *Journal of materials processing technology* 190(2007), pp.51-60, 2007.
6. A.Ghobeity , D. Ciampini, M. Papini. ,,,Effect of particle size distribution on the surface profile”. *Journal of Materials Processing Technology* 209 pp. 6067–607 2009
7. A.El-Domiaty, H. M. Abd El-Hafez and M.A. Shaker. ,,,Drilling of Glass Sheets by Abrasive Jet Machining. "" *World Academy of science, Engineering and Technology*, vol.3, pp.57-63, Aug.2009.
8. Shanmugam D. K., Masood S. H. 2009. An investigation of kerf characteristics in abrasive watejet cutting of layered composites, *International Journal of Material Processing Technology* 209: pp 3887–3893
9. Stephen Wan, Weng Seng Fong, Qi Ying Leong-Deterministic Process Modelling of Micro Air Abrasive Jet Machining of Glass Channel- 2010, *Key Engineering Materials*, 447-448, 272.
10. R. Balasubramaniam, J. Krishan, N. Ramakrishnan. “ An empirical study on the generation of edge radius in abrasive jet external deburring (AJED), *J.Mater..Process..Technol.* 99(2000) 49.
11. R.H.M. Jafar\*1, M. Papini2, 1, J.K. Spelt1, 2, Surface roughness and erosion rate of abrasive jet micro machined channels: Experiments and analytical model,-2013-Elsevier.
12. Jukti Prasadn Padhy, “Optimization and effect of controlling parameters on AJM using Taguchi technique”*Int. Journal of Engineering Research and Applications* ISSN : 2248-9622, Vol. 4, Issue 3 (Version 1), pp.598-604, March 2014.
13. V. C. Venkatesh, T. N. Goh, K. H. Wong, M. J. Lim - An empirical study of parameters in Abrasive Jet Machining 1989, *Int Journal of Machine Tools and Mfg.*
14. Mr. Bhaskar Chandra. ,A Study of effects of Process Parameters of Abrasive jet machining.” *International Journal of Engineering Science and Technology*, vol.3, pp.504-513, Jan. 2011